



**Electric
Vehicle
Gel**

HAZE

Power to keep
you on the move

www.hazebattery.com

ELECTRIC VEHICLE applications are wide and varied with many durability & power demands placed firmly on the batteries shoulders.

HAZE ELECTRIC VEHICLE GEL always delivers when you need it, whatever your DC requirement in extreme situations.



Tough ABS case with INSERT TERMINALS as standard, smaller sizes with FASTON.

Special Active Material Formulation & Gel Technology delivers cranking amps, general power and long/deep discharges without the need for immediate recharge.

EXTRA LONG CYCLE LIFE and resistance to mechanical stress and the elements all in one battery.

	Dimensions mm - kg						Dimensions Inches - lbs						Cold Cranking Amps		
	Length	Width	Height Auto	Height Insert	Height Battery	Weight	Length	Width	Height Auto	Height Insert	Height Battery	Weight	20°C (68°F)	0°C (32°F)	-18°C (0°F)
HZY-EV12-135	340	173	303	286	283	41.9	13.39	6.81	11.9	11.3	11.1	88.0	998	906	762

	Volts	Thread size mm	Reserve Capacity - Mins					Capacity - Ampere Hour*							
			75 Amps	25 Amps	20 Amps	15 Amps	8 Amps	100 Hr	48 Hr	20 Hr	10 Hr	5 Hr	3 Hr	1 Hr	
HZY-EV12-135	12	8	84	276	368	519	1064	186	174	162	146	133	119	94.8	

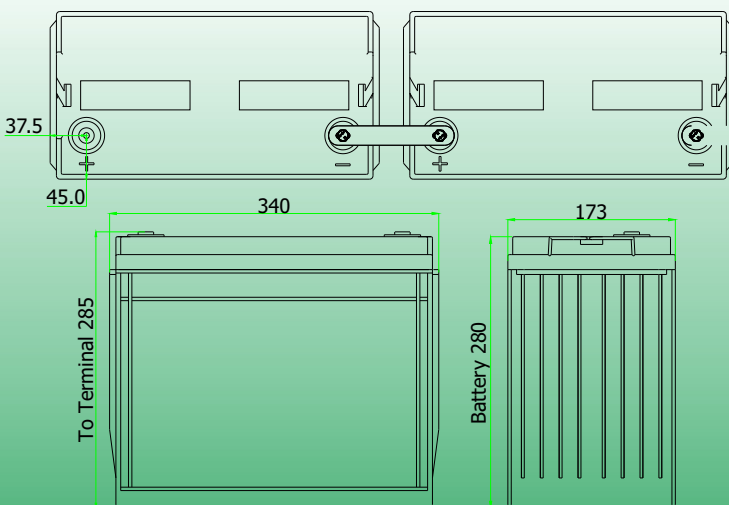

EV Charging - To obtain maximum cycle life from your EV battery it is important that a suitable charging profile is used. For information about the Haze range of chargers and the **Haze recommended charging profile** contact your local Haze distributor.

NOTE: All Haze Gel batteries are true Gel batteries, plate chemistry is specifically for cyclic applications, the microporous polymer gel separator and the gelling agents are European made and imported specially for Gel production.

HAZE ELECTRIC VEHICLE GEL delivers maximum capacity within twenty cycles and keeps delivering long after the others are on the scrap heap. HAZE R&D has resulted in **SPECIAL CHEMICAL** and **PROCESS** technology to ensure consistency and performance.

150210